

De Projectinrichter

www.deprojectinrichter.com

Bel gratis 0800-566 66 66

Sono

Bekijk hier de complete [Renz](#) kantoormeubelen collectie







Sono (Design: Justus Kolberg)

Die Umgebung beeinflusst unser Denken und Handeln. Sono besticht durch architektonische Qualität und kluge Funktionalität. Das Prinzip Baukasten steht hier als Gestaltungsgrundsatz, dem das vielseitige Arbeitsplatzsystem konsequent folgt. Container bilden, individuell zusammengestellt, praktische Toolboards für den Stauraum und integrieren intelligent modernste Kommunikationstechnik. Markante Aluminiumrahmen stützen Schreibtische in unterschiedlichen Tischplattenlängen, wahlweise in edlem Furnier oder aus Glas. Weitere Optionen: Runde und rechteckige Besprechungstische sowie elektromotorisch höhenverstellbare Arbeitsplätze.

Sono (Design: Justus Kolberg)

Our environment influences how we think and act. Sono's captivating features are architectural quality and clever functionality. Modularity is the basic design principle, and the multifaceted workplace system carries it out to perfection. Containers are grouped together as desired, forming practical toolboards for storage and neatly integrating the latest in modern communications technology. Striking aluminium frames support desks of various lengths in glass or fine veneer. Other options include round and rectangular conference tables as well as electrically driven height-adjustable tabletops.





Sono

Maße/Dimensions

Schreibtisch mit 2 Rahmen. Desk with 2 frames.

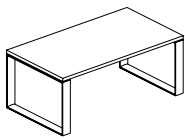

180 x 100
Höhe hight 73/75

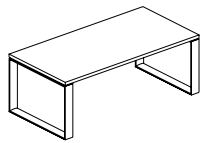

200 x 100
Höhe hight 73/75

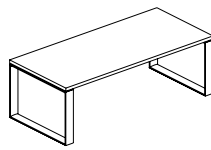

220 x 100
Höhe hight 73/75

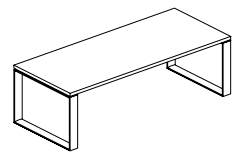

240 x 100
Höhe hight 73/75

Höhenverstellbarer Schreibtisch mit 2 Säulen. Hight-adjustable desk with 2 columns.

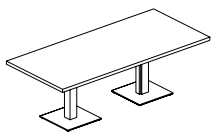

220 x 100
Höhe hight 73 - 121

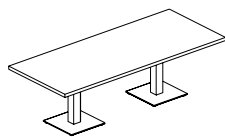

240 x 100
Höhe hight 73 - 121

Schreibtischplatte* mit angebautem Toolboard. Top* with toolboard.

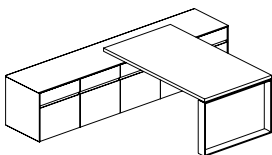

*180 x 100
Höhe hight 73/75

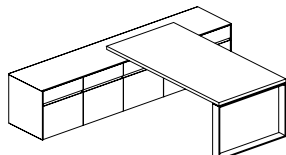

*200 x 100
Höhe hight 73/75

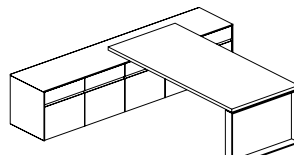

*220 x 100
Höhe hight 73/75

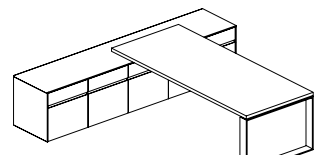

*240 x 100
Höhe hight 73/75

Höhenverstellbare Schreibtischplatte* mit 2 Säulen - Eine Säule ist im Toolboard integriert.
Hight-adjustable top* with 2 columns - One column is integrated in the toolboard.

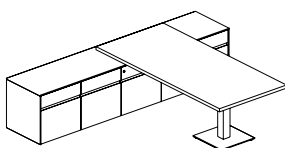

*220 x 100
Höhe hight 73 - 121

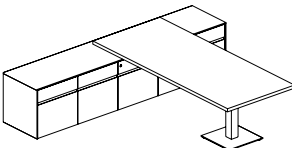

*240 x 100
Höhe hight 73 - 121

Container. Container.

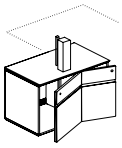

100 x 60
Höhe hight 64

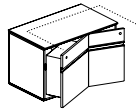

100 x 60
Höhe hight 64

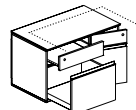

100 x 60
Höhe hight 64



60 x 60
Höhe hight 64



60 x 60
Höhe hight 64



60 x 60
Höhe hight 64



30 x 60
Höhe hight 64

Abschluss-Seite. End panel.



1,2 x 60
Höhe hight 64

Roll-Container. Mobile container.



62,5 x 60
Höhe hight 58



62,5 x 60
Höhe hight 58

Sono

Maße/Dimensions

Besprechungstisch. Meeting table.

für 4 Personen
for 4 people



Ø 110
Höhe hight 73

für 5 Personen
for 5 people



Ø 125
Höhe hight 73

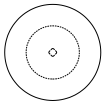

K 24

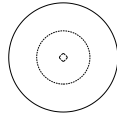

K 25

für 4 Personen
for 4 people

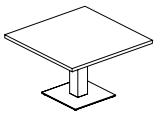

120 x 120
Höhe hight 73

für 6 Personen
for 6 people

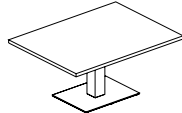

160 x 120
Höhe hight 73

für 8 Personen
for 8 people

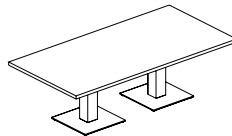

240 x 120
Höhe hight 73



K 26
K 36*

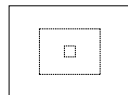

K 27
K 37*

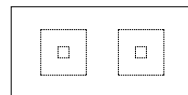

K 28
K 38*

* höhenverstellbar/adjustable in height

Beispielhafte Toobboardkonfiguration. Exemplary toolboard configuration.

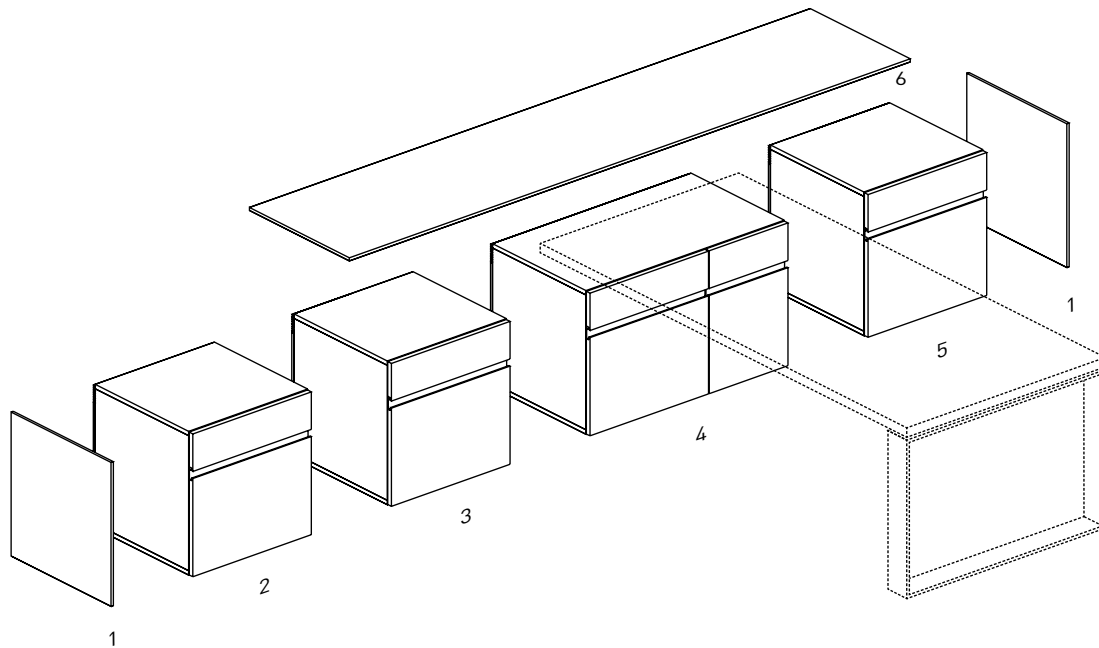

1. Abschluss-Seite. End panel. 2. Container K45 mit einer Schublade, Innenschublade und Hängeregistratur. Container K45 with one drawer, a drawer inside and a file extension. 3. Container K 46 mit einer Schublade und einer Schublade für Drucker (incl. Lüftung). Container K 46 with one drawer and one drawer for printer (with ventilation) 4. Container K 40 zur Auflage der Tischplatte mit 2 Türen und einer PC-Halterung. Container K 40 to support the desk top, with 2 doors and a PC-fitting. 5. Container K 43 mit einer Tür, bspw. für den Einbau eines Kühlschranks. Container K 43 with one door, e.g. for the Build-in fridge. 6. Abdeckplatte bis zu der Länge von 283 cm einteilig. Covering panel in a single section up to the length of 283 cm.

Beispielhafte Schreibtischkonfiguration. Exemplary desk configuration.

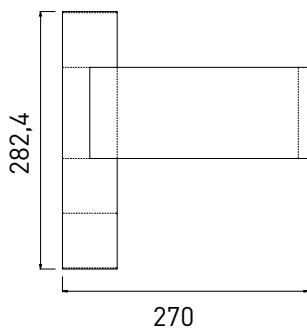

Schreibtischkonfiguration bestehend aus:

Tischplatte K11	240,0 x 100,0
Rahmen K 20	11,3 x 100,0
2 x Abschluss-Seite K49	1,2 x 60,0
Container K 45	60,0 x 60,0
Container K 46	60,0 x 60,0
Container K 40	100,0 x 60,0
Container K 43	60,0 x 60,0

Desktop configuration consisting of:

Top K11	240,0 x 100,0
Frame K 20	11,3 x 100,0
2 x End panel K49	1,2 x 60,0
Container K 45	60,0 x 60,0
Container K 46	60,0 x 60,0
Container K 40	100,0 x 60,0
Container K 43	60,0 x 60,0

Sono
Details/Details

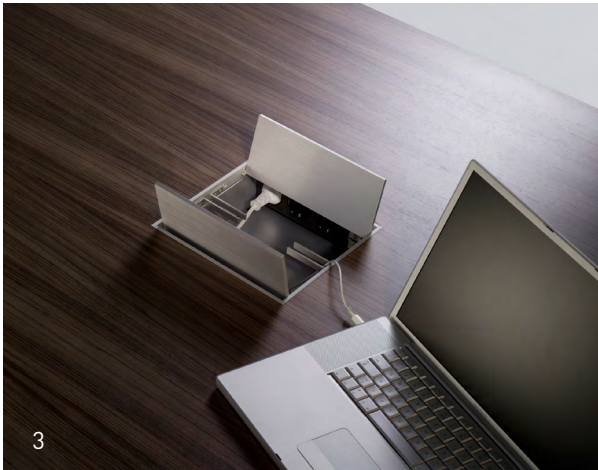
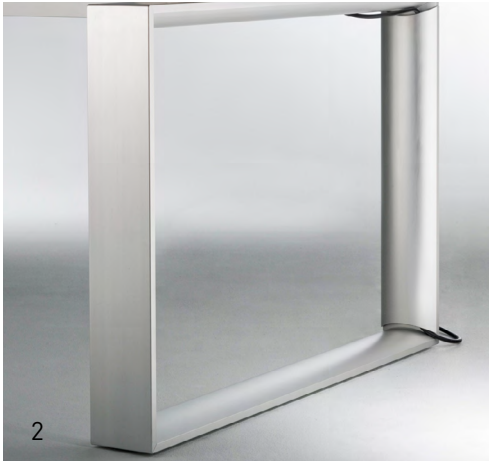

1. Unter der Lederschiebepplatte befinden sich Ablagemöglichkeiten und Anschlüsse für elektronische Medien.
2. Vertikale Kabelführung am Rahmen aus eloxiertem Aluminium.
3. Doppel-Elektrobox aus eloxiertem Aluminium.
4. Unter dem Schiebetablar befindet sich eine Elektroleiste mit 3 Steckdosen und 2 RJ45-Anschlüssen.
5. Die Rückseite des Toolboards mit Lüftungsgittern.
6. Elektromotorisch verstellbare Hubsäule.

1. Storage space and connectors for electronic media are underneath the sliding leather top.
2. Vertical cabling at the frame made of anodized aluminum.
3. Double power box made of anodized aluminum.
4. The sliding tray covers a powerstrip with 3 sockets and 2 RJ45-sockets.
5. The backside of the toolboard with grilles for ventilation.
6. Electromotive adjustable lifting column.



Ahorn hell
Maple light



Buche natur
Beech natural



Birnbaum natur
Pear natural



Am. Kirschbaum natur
Am. Cherry natural



Eiche hell
Oak light

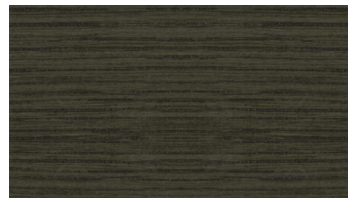

Eiche titangrau
Oak grey titan

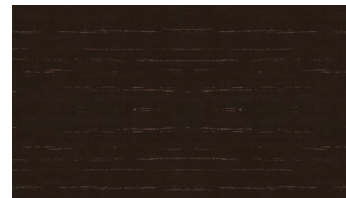

Eiche mocca
Oak mocca



Räuchereiche
Oak smoked

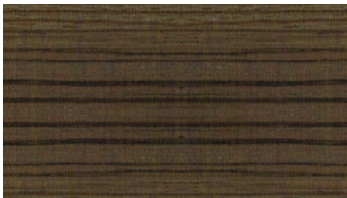

Zebrano grau
Zebrano grey



Am. Nussbaum natur
Am. Walnut natural



Nussbaum tabac
Walnut tobacco



Zebrano natur
Zebrano natural

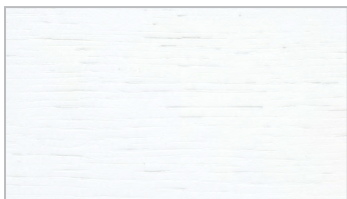

Eiche weiß
Oak white

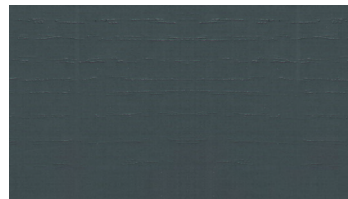

Eiche graphitgrau
Oak graphite grey



Eiche schwarz
Oak black

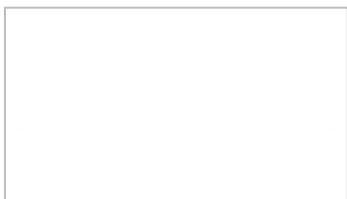

Lack Hochglanz/seidenmatt weiß
Lacquer high gloss/silk matt white



Lack Hochglanz/seidenmatt crema
Lacquer high gloss/silk matt crema



Lack Hochglanz/seidenmatt anthrazit
Lacquer high gloss/silk matt anthracite



Lack Hochglanz/seidenmatt akzentrot
Lacquer high gloss/silk matt accent red

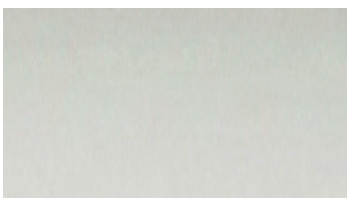

Lack alusilber
Lacquer aluminium silver

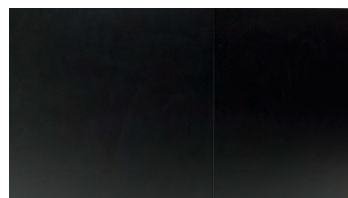

Lack schwarz metallic
Lacquer black metallic

Die abgebildeten Farben sind nicht farbverbindlich. Die Darstellung kann je nach Monitor und Drucker variieren. Weitere Oberflächenausführungen wie Furniere, Laminat, und Linoleum nach Muster auf Anfrage.
The colours shown are intended as a guideline only. Their representation may vary depending on the monitor and printer. Further surface finishes such as natural wood veneer, laminate and linoleum on request by sample.

De Projectinrichter

www.deprojectinrichter.com

Bel gratis 0800-566 66 66